

FABRYKA MASZYN ELEKTRYCZNYCH S.A.

**indukta**

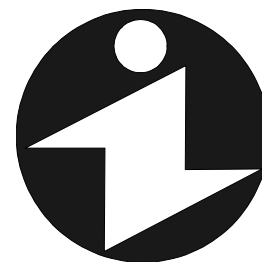

# KARTA KATALOGOWA CATALOGUE CARD

Trójfazowe silniki indukcyjne jednobiegowe  
z wirnikiem klatkowym  
klasy EFF2

Three-phase induction one speed motors  
with squirrel-cage rotor  
EFF2 class

**Cantoni**®  
**GROUP**

TELEFON: [48] [33] 827-20-00 ÷ 04  
FAX: [48] [33] 827-20-97 ÷ 99  
e-mail: [indukta@cantonimotor.com.pl](mailto:indukta@cantonimotor.com.pl)  
<http://www.indukta.com.pl>

**Charakterystyka wykonania:**

- moce znamionowe podane są dla pracy S1,
- napięcie znamionowe 380, 400 lub 500 [V],
- częstotliwość napięcia zasilania 50 lub 60 [Hz],
- temperatura otoczenia od -15 do +40[°C],
- wysokość instalowania do 1000 [m] n.p.m.,
- izolacja klasy F,
- stopień ochrony IP 55,
- z jednym czopem końcowym wału wg rysunku wymiarowego,
- skrzynka zaciskowa z dławnicami i tabliczką 6-zaciskową.

**Wykonania na życzenia:**

- z dwoma walcowymi czopami wału wg rysunku wymiarowego,
- z termistorowymi czujnikami temperatury w czołach uzwojenia,
- przystosowane do pracy w klimacie tropikalnym TH, TA lub MT (w wykonaniu TA lub MT ze względu na podwyższone temperatury otoczenia może być konieczna obniżka mocy znamionowej),
- fabryka wykonuje również silniki różniące się od wykonania podstawowego po uprzednim uzgodnieniu szczegółów konstrukcyjnych i terminów dostaw.

**Sposób zamawiania:**

- W zamówieniu należy podać pełne określenie typu silnika, moc, prędkość obrotową, napięcie zasilające, układ połączeń, częstotliwość, formę wykonania oraz inne szczegóły niekatalogowego lub specjalnego wykonania,
- Silniki z wałem do pracy na zewnątrz z wałem skierowanym w dół powinny być zamawiane z specjalnym daszkiem ochronnym chroniącym przed np.: deszczem, śnieg itp.

**Features:**

- rated outputs for continuous duty,
- rated voltage 380, 400 or 500 [V],
- frequency 50 or 60 [Hz],
- environment temperature -15 to +40[°C],
- altitude up to 1000 [m] above sea level,
- insulation class F,
- protection degree IP 55,
- one free shaft extension according to dimension drawing,
- terminal box with glands and 6 terminal board with 6 terminals.

**Features on request:**

- two cylindrical shaft extensions according to dimension drawing,
- temperature - sensitive resistors in the winding ends,
- fit for work in tropical climate TH, TA or MT (for TA or MT rated output could be decreased due to higher environment temperature),
- factory produces various types of motors but constructional details and delivery time are to be individual agreed

**How to order:**

- In the order there must be clearly given: full designation of the motor, rated output, rated speed, rated voltage, phase connection, frequency, mounting form and all other details for non catalogue execution,
- The motors for outdoor operation in vertical position with shaft end downwards should be ordered with special protective cap against e.g. rain, snow, etc.

Producent zastrzega sobie prawo zmian parametrów eksploatacyjnych przedstawionych w katalogu.  
The manufacturer reserves the right to modify the performances of the products shown in this catalogue.

## PARAMETRY EKSPLOATACYJNE SILNIKÓW PERFORMANCES OF MOTORS

Typ silnika  Type of motor	P <sub>n</sub>  Rated output		n <sub>n</sub>  Rated speed	M <sub>n</sub>  Rated Torque	η <sub>n</sub>  Efficiency	cos φ <sub>n</sub>  Power factor	I <sub>1n</sub> przy nap. znam.  Full-load amps at			m <sub>rn</sub>  Locked rotor torque	i <sub>rn</sub>  Locked rotor current	m <sub>maxn</sub>  Break-down torque	J  Moment of inertia	L <sub>WA</sub>  Sound power level	L <sub>PA</sub>  Sound pressure level	Masa IM B3  Weight IM B3
	[kW]	[HP]	[min <sup>-1</sup> ]	[Nm]	[%]	-	[A] 380V	[A] 400V	[A] 500V	[%]	[%]	[%]	[kgm <sup>2</sup> ]	[dB]	[dB]	[kg]
<b>2p=2 ns=3000 obr/min rpm=3000</b>																
Sg 80-2A	0,75	1,0	2850	2,5	78,0	0,80	1,8	1,7	1,4	240	550	270	0,0008	75	65	11,0
Sg 80-2B	1,10	1,5	2860	3,7	78,2	0,78	2,7	2,6	2,1	235	555	280	0,0011	75	65	11,0
Sh 90S-2	1,5	2,0	2835	5,1	81,1	0,83	3,4	3,2	2,6	300	615	305	0,0013	78	68	14,0
Sh 90L-2	2,2	3,0	2855	7,4	83,2	0,82	4,9	4,7	3,7	340	710	350	0,0020	78	68	16,8
Sg 100L-2	3,0	4,0	2905	9,9	83,4	0,86	6,4	6,0	4,8	270	750	280	0,0048	81	71	25,0
Sg 112M-2	4,0	5,5	2865	13,3	85,4	0,90	7,9	7,5	6,0	210	640	230	0,0079	81	71	34,0
Sg 132S-2A	5,5	7,5	2910	18,0	87,0	0,88	10,9	10,4	8,3	240	700	320	0,0150	81	70	60,0
Sg 132S-2B	7,5	10,0	2920	24,5	88,5	0,88	14,6	13,9	11,1	250	750	320	0,0180	85	74	71,0
Sg 160M-2A	11,0	15,0	2945	35,7	90,0	0,87	20,9	20,3	16,2	220	770	340	0,0420	84	73	96,0
Sg 160M-2B	15,0	20,0	2935	48,8	91,0	0,89	28,1	26,7	21,4	200	720	260	0,0480	84	73	103,0
Sg 160L-2	18,5	25,0	2930	60,3	90,3	0,91	34,2	32,5	26,0	210	680	290	0,0590	84	73	119,0
Sg 180M-2	22,0	30,0	2920	72,0	90,6	0,88	41,9	39,8	31,9	250	600	250	0,0760	88	77	165,0
Sg 200L-2A	30,0	40,0	2940	97,4	90,1	0,89	56,8	54,0	43,2	270	650	260	0,1450	90	79	199,0
<b>2p=4 ns=1500 obr/min rpm=1500</b>																
Sg 80-4A	0,55	0,75	1430	3,7	74,4	0,76	1,5	1,4	1,1	205	480	295	0,0017	65	55	11,0
Sg 80-4B	0,75	1,00	1425	5,0	75,4	0,77	2,0	1,9	1,5	195	490	275	0,0019	65	55	11,9
Sh 90S-4	1,1	1,5	1405	7,5	76,7	0,80	2,7	2,6	2,1	220	490	280	0,0023	66	56	14,0
Sh 90L-4	1,5	2,0	1410	10,2	79,0	0,78	3,7	3,5	2,8	250	530	280	0,0028	66	56	16,5
Sg 100L-4A	2,2	3,0	1425	14,7	82,0	0,80	5,1	4,8	3,9	250	610	280	0,0058	70	60	25,0
Sg 100L-4B	3,0	4,0	1415	20,2	82,7	0,81	6,8	6,5	5,2	260	610	270	0,0065	70	60	26,0
Sg 112M-4	4,0	5,5	1435	26,6	85,1	0,82	8,7	8,3	6,6	260	630	300	0,0118	72	62	34,0
Sg 132S-4	5,5	7,5	1450	36,2	85,9	0,84	11,6	11,0	8,8	220	690	310	0,0290	75	64	62,0
Sg 132M-4	7,5	10,0	1450	49,4	87,0	0,85	15,4	14,6	11,7	240	670	310	0,0350	75	64	73,0
Sg 160M-4	11,0	15,0	1460	72,0	89,0	0,85	22,1	21,0	16,8	230	700	310	0,0610	74	63	105,0
Sg 160L-4	15,0	20,0	1460	98,1	89,5	0,87	29,3	27,8	22,2	240	730	320	0,0750	77	66	125,0
Sg 180M-4	18,5	25,0	1470	120,2	90,5	0,90	34,5	32,8	26,2	240	680	290	0,1350	80	69	165,0
Sg 180L-4	22,0	30,0	1465	143,4	91,0	0,90	40,8	38,8	31,0	270	730	280	0,1550	80	69	175,0
Sg 200L-4	30,0	40,0	1465	195,6	91,4	0,90	55,4	52,6	42,1	280	750	270	0,3050	81	70	211,0
<b>2p=6 ns=1000 obr/min rpm=1000</b>																
Sh 90S-6	0,75	1,0	915	7,8	72,4	0,72	2,2	2,1	1,7	190	370	220	0,0020	63	53	13,5
Sh 90L-6	1,10	1,5	920	11,4	75,4	0,71	3,1	3,0	2,4	220	400	225	0,0028	63	53	16,5
Sg 100L-6	1,50	2,0	945	15,2	76,7	0,73	4,1	3,9	3,1	190	460	230	0,0090	64	54	24,0
Sg 112M-6	2,20	3,0	960	21,9	83,8	0,78	5,1	4,9	3,9	220	590	280	0,0177	70	60	33,0
Sg 132S-6	3,00	4,0	950	30,2	81,0	0,78	7,2	6,9	5,5	210	540	280	0,0250	73	62	54,0
Sg 132M-6A	4,00	5,5	950	40,2	84,0	0,79	9,2	8,7	7,0	240	600	310	0,0320	73	62	66,0
Sg 132M-6B	5,50	7,5	950	55,3	85,0	0,79	12,4	11,8	9,5	270	630	310	0,0400	73	62	72,0
Sg 160M-6	7,50	10,0	960	74,6	87,5	0,81	16,1	15,3	12,2	230	650	310	0,0720	73	62	100,0
Sg 160L-6	11,00	15,0	960	109,4	88,5	0,82	23,0	21,9	17,5	240	700	310	0,0960	73	62	125,0
Sg 180L-6	15,00	20,0	975	146,9	89,0	0,84	30,5	29,0	23,2	280	600	240	0,2200	76	65	170,0
<b>2p=8 ns=750 obr/min rpm=750</b>																
Sh 90S-8	0,37	0,50	695	5,1	63,4	0,59	1,5	1,4	1,1	170	295	230	0,0021	61	51	13,4
Sh 90L-8	0,55	0,75	675	7,8	65,0	0,64	2,0	1,9	1,5	170	280	190	0,0024	62	52	15,3
Sg 100L-8A	0,75	1,00	710	10,1	71,1	0,66	2,4	2,3	1,8	145	350	190	0,0090	64	54	23,6
Sg 100L-8B	1,10	1,50	705	14,9	72,2	0,65	3,6	3,4	2,7	160	360	190	0,0100	64	54	26,3
Sg 112M-8	1,50	2,00	720	19,9	76,8	0,71	4,2	4,0	3,2	190	460	230	0,0192	67	57	31,0
Sg 132S-8	2,20	3,00	710	29,6	78,0	0,74	5,8	5,5	4,4	200	470	240	0,0330	71	60	53,0
Sg 132M-8	3,00	4,00	710	40,4	80,0	0,74	7,7	7,3	5,9	230	500	300	0,0440	71	60	65,0
Sg 160M-8A	4,00	5,50	705	54,2	81,5	0,76	9,8	9,3	7,5	220	500	270	0,0600	72	61	85,0
Sg 160M-8B	5,50	7,50	710	74,0	83,0	0,75	13,4	12,8	10,2	270	550	300	0,0770	72	61	95,0
Sg 160L-8	7,50	10,00	705	101,6	84,5	0,78	17,3	16,4	13,1	270	580	300	0,1020	72	61	115,0
Sg 180L-8	11,00	15,00	730	143,9	89,0	0,76	24,7	23,5	18,8	200	550	240	0,2130	76	65	165,0

### Wymiary montażowe silników na łapach Mounting dimensions for foot-mounted motors

Typ Type	A	B	C	D,DA	E,EA	F,FA	GA,GC	H	K
	[mm]								
Sg 80...	125	100	50	19j6	40	6h9	21,5	80	10
Sh 90S ...	140	100	56	24j6	50	8h9	27,0	90	10
Sh 90L ...	140	125	56	24j6	50	8h9	27,0	90	10
Sg 100L ...	160	140	63	28j6	60	8h9	31,0	100	12
Sg 112M ...	190	140	70	28j6	60	8h9	31,0	112	12
Sg 132S ...	216	140	89	38k6	80	10h9	41,0	132	12
Sg 132S-2B	216	140	89	38k6	80	10h9	41,0	132	12
Sg 132M ...	216	178	89	38k6	80	10h9	41,0	132	12
Sg 160M ...	254	210	108	42k6	110	12h9	45,0	160	15
Sg 160L ...	254	254	108	42k6	110	12h9	45,0	160	15
Sg 180M ...	279	241	121	48k6	110	14h9	51,5	180	15
Sg 180L ...	279	279	121	48k6	110	14h9	51,5	180	15
Sg 200L...	318	305	133	55m6	110	16h9	59,0	200	19

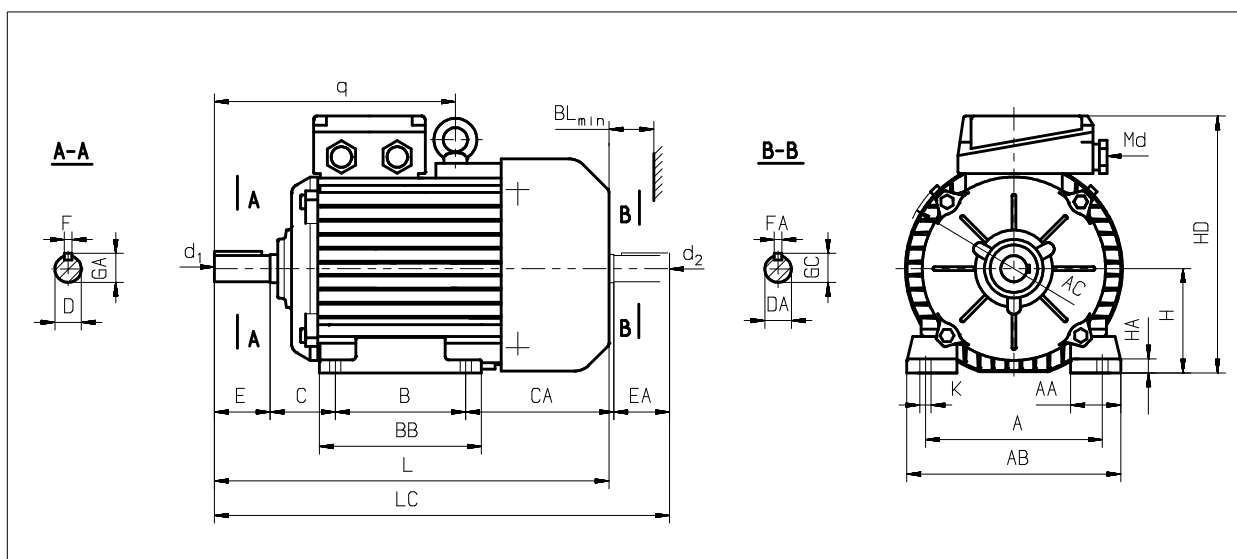

### Wymiary gabarytowe silników na łapach Overall dimensions for foot-mounted motors

Typ Type	AA	AB	AC	BB	BL	CA	d1,d2	HA	HD	L	LC	q	Md	Łożysko nr Bearing No
	[mm]													
Sg 80...A	22	145	178	120	15	83	M6	2,5	205	268	313	-	M 20 x 1,5	6204 2Z
Sg 80...B	22	145	178	120	15	90	M6	2,5	205	275	320	-	M 20 x 1,5	6204 2Z
Sh 90S ...	50	170	185	153	15	104	M8	10	220	305	360	-	M 20 x 1,5	6205 2Z
Sh 90L ...	50	170	185	153	15	104	M8	10	220	330	385	-	M 20 x 1,5	6205 2Z
Sg 100L ...	45	200	206	172	20	116	M10	14	240	376	441	-	M 20 x 1,5	6206 2Z
Sg 112M ...	54	230	245	174	20	119	M10	14	276	384	449	257	M 25 x 1,5	6306 2Z
Sg 132S ...	56	278	274	182	40	160	M12	16	310	463	549	284	M 25 x 1,5	6308 2Z
Sg 132S-2B	56	278	274	220	40	198	M12	16	310	501	587	284	M 25 x 1,5	6308 2Z
Sg 132M ...	56	278	274	220	40	160	M12	16	310	501	587	284	M 25 x 1,5	6308 2Z
Sg 160M ...	60	305	323	256	40	200	M16	20	370	612	738	350	M 40 x 1,5	6309 2Z
Sg 160L ...	60	305	323	300	40	200	M16	20	370	656	782	350	M 40 x 1,5	6309 2Z
Sg 180M ...	70	350	360	320	40	243	M16	26	408	705	825	358	M 40 x 1,5	6311 2Z
Sg 180L ...	70	350	360	320	40	205	M16	26	408	705	825	358	M 40 x 1,5	6311 2Z
Sg 200L ...	80	400	360	350	40	215	M16	32	428	754	873	388	M 40 x 1,5	6213 2Z 6311 2Z

Wymiar AB dla silników wielkości 132 z łapami odlewanymi wraz z korpusem wynosi 260 mm.

As to motors of size „132” the dimension AB amounts to 260 mm in case the feet are together with frame casted.

#### Formy wykonania:

- IM 1001, IM 1011, IM 1031, IM 1051, IM 1061, IM 1071 - wg IEC 60034-7, PN-EN 60034-7
- IM B3, IM B6, IM B7, IM B8, IM V5, IM V6 - wg IEC 60034-7, PN-EN 60034-7

#### Mounting forms:

- IM 1001, IM 1011, IM 1031, IM 1051, IM 1061, IM 1071 - per IEC 60034-7
- IM B3, IM B6, IM B7, IM B8, IM V5, IM V6 - per IEC 60034-7

## Wymiary montażowe silników kołnierzych Mounting dimensions for flange-mounted motors

Typ Type	D,DA	E,EA	F,FA	GA,GC	M	N	P	S	T
	[mm]								
SKg 80 ...	19j6	40	6h9	21,5	165	130j6	200	12	3,5
SKh 90S ...	24j6	50	8h9	27,0	165	130j6	200	12	3,5
SKh 90L ...	24j6	50	8h9	27,0	165	130j6	200	12	3,5
SKg 100L ...	28j6	60	8h9	31,0	215	180j6	250	15	4,0
SKg 112M ...	28j6	60	8h9	31,0	215	180j6	250	15	4,0
SKg 132S ...	38k6	80	10h9	41,0	265	230j6	300	15	4,0
SKg 132S-2B	38k6	80	10h9	41,0	265	230j6	300	15	4,0
SKg 132M ...	38k6	80	10h9	41,0	265	230j6	300	15	4,0
SKg 160M ...	42k6	110	12h9	45,0	300	250j6	350	19	5,0
SKg 160L ...	42k6	110	12h9	45,0	300	250j6	350	19	5,0
SKg 180M ...	48k6	110	14h9	51,5	300	250j6	350	19	5,0
SKg 180L ...	48k6	110	14h9	51,5	300	250j6	350	19	5,0
SKg 200L ...	55m6	110	16h9	59,0	350	300j6	400	19	5,0

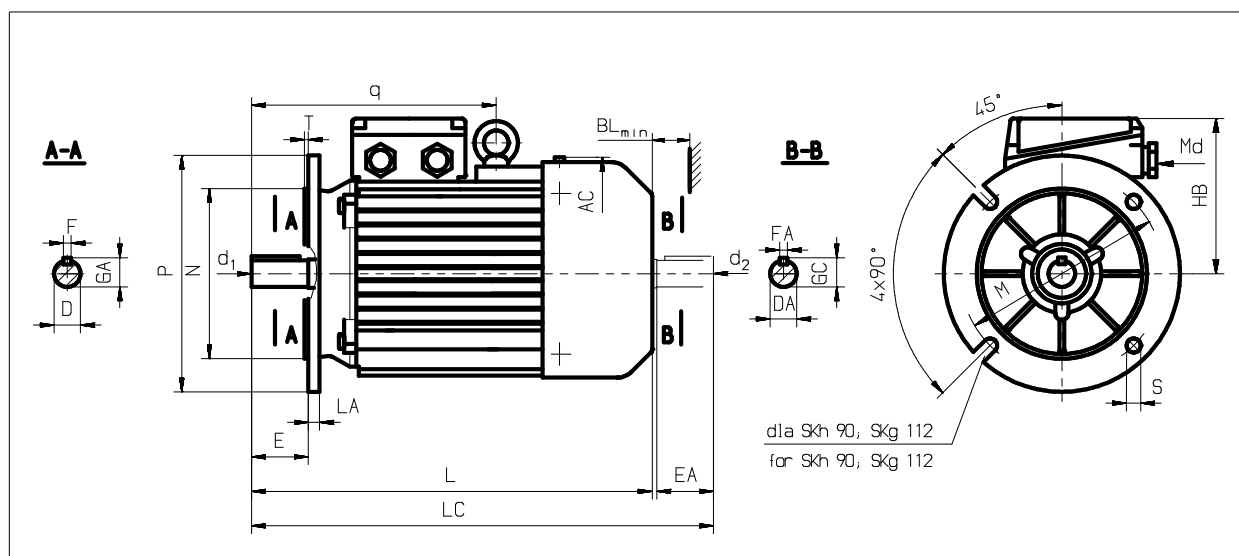

## Wymiary gabarytowe silników kołnierzych Overall dimensions for flange-mounted motors

Typ Type	AC	BL	d1,d2	HB	L	LA	LC	q	Md	Łożysko nr Bearing No
	[mm]									
SKg 80-...A	178	15	M6	125	268	8	313	-	M 20 x 1,5	6204 2Z
SKg 80-...B	178	15	M6	125	275	8	320	-	M 20 x 1,5	6204 2Z
SKh 90S ...	185	15	M8	130	305	8	360	-	M 20 x 1,5	6205 2Z
SKh 90L ...	185	15	M8	130	330	8	385	-	M 20 x 1,5	6205 2Z
SKg 100L ...	206	20	M10	140	376	11	441	-	M 20 x 1,5	6206 2Z
SKg 112M ...	245	20	M10	164	384	12	449	257	M 25 x 1,5	6306 2Z
SKg 132S ...	274	40	M12	178	463	12	549	284	M 25 x 1,5	6308 2Z
SKg 132S-2B	274	40	M12	178	501	12	587	284	M 25 x 1,5	6308 2Z
SKg 132M ...	274	40	M12	178	501	12	587	284	M 25 x 1,5	6308 2Z
SKg 160M ...	323	40	M16	210	612	13	738	350	M 40 x 1,5	6309 2Z
SKg 160L ...	323	40	M16	210	656	13	782	350	M 40 x 1,5	6309 2Z
SKg 180M ...	360	40	M16	228	705	13	825	358	M 40 x 1,5	6311 2Z
SKg 180L ...	360	40	M16	228	705	13	825	358	M 40 x 1,5	6311 2Z
SKg 200L ...	360	40	M16	228	754	16	873	388	M 40 x 1,5	6213 2Z 6311 2Z

### Formy wykonania:

- IM 3001, IM 3011, IM 3031 - wg IEC 60034-7, PN-EN 60034-7
- IM B5, IM V1, IM V3 - wg IEC 60034-7, PN-EN 60034-7

### Mounting forms:

- IM 3001, IM 3011, IM 3031 - per 600IEC 34-7
- IM B5, IM V1, IM V3 - per IEC 60034-7

## Wymiary montażowe silników kołnierzowych na łapach Mounting dimensions for foot-flange-mounted motors

Typ Type	A	B	C	D,DA	E,EA	F,FA	GA,GC	H	K	M	N	P	S	T
	[mm]													
SLg 80 ...	125	100	50	19j6	40	6h9	21,5	80	10	165	130j6	200	12	3,5
SLh 90S ...	140	100	56	24j6	50	8h9	27,0	90	10	165	130j6	200	12	3,5
SLh 90L ...	140	125	56	24j6	50	8h9	27,0	90	10	165	130j6	200	12	3,5
SLg 100L ...	160	140	63	28j6	60	8h9	31,0	100	12	215	180j6	250	15	4,0
SLg 112M ...	190	140	70	28j6	60	8h9	31,0	112	12	215	180j6	250	15	4,0
SLg 132S ...	216	140	89	38k6	80	10h9	41,0	132	12	265	230j6	300	15	4,0
SLg 132S-2B	216	140	89	38k6	80	10h9	41,0	132	12	265	230j6	300	15	4,0
SLg 132M ...	216	178	89	38k6	80	10h9	41,0	132	12	265	230j6	300	15	4,0
SLg 160M ...	254	210	108	42k6	110	12h9	45,0	160	15	300	250j6	350	19	5,0
SLg 160L ...	254	254	108	42k6	110	12h9	45,0	160	15	300	250j6	350	19	5,0
SLg 180M ...	279	241	121	48k6	110	14h9	51,5	180	15	300	250j6	350	19	5,0
SLg 180L ...	279	279	121	48k6	110	14h9	51,5	180	15	300	250j6	350	19	5,0
SLg 200L ...	318	305	133	55m6	110	16h9	59,0	200	19	350	300j6	400	19	5,0

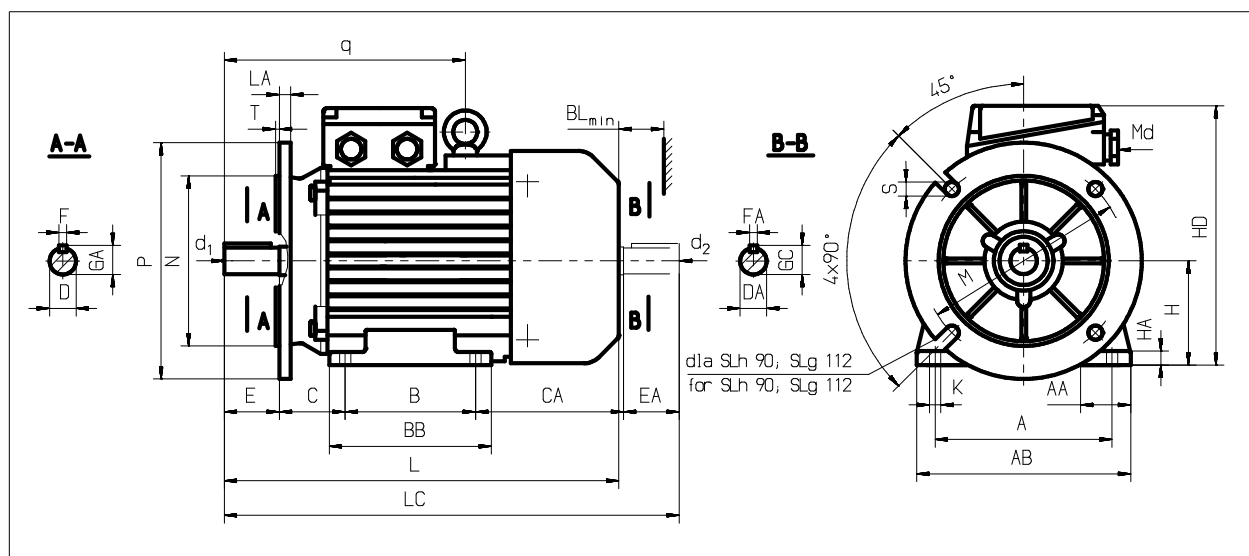

## Wymiary gabarytowe silników kołnierzowych na łapach Overall dimensions for foot-flange-mounted motors

Typ Type	AA	AB	BB	BL	CA	d1,d2	HA	HD	L	LA	LC	q	Md	Łożysko nr Bearing No
	[mm]													
SLg 80-...A	22	145	120	15	83	M6	2,5	205	268	8	313	-	M 20 x 1,5	6204 2Z
SLg 80-...B	22	145	120	15	90	M6	2,5	205	275	8	320	-	M 20 x 1,5	6204 2Z
SLh 90S ...	50	170	153	15	104	M8	10	220	305	8	360	-	M 20 x 1,5	6205 2Z
SLh 90L ...	50	170	153	15	104	M8	10	220	330	8	385	-	M 20 x 1,5	6205 2Z
SLg 100L ...	45	200	172	20	116	M10	14	240	376	11	441	-	M 20 x 1,5	6206 2Z
SLg 112M ...	54	230	174	20	119	M10	14	276	384	12	449	257	M 25 x 1,5	6306 2Z
SLg 132S ...	56	278	182	40	160	M12	16	310	463	12	549	284	M 25 x 1,5	6308 2Z
SLg 132S-2B	56	278	220	40	198	M12	16	310	501	12	587	284	M 25 x 1,5	6308 2Z
SLg 132M ...	56	278	220	40	160	M12	16	310	501	12	587	284	M 25 x 1,5	6308 2Z
SLg 160M ...	60	305	256	40	200	M16	20	370	612	13	738	350	M 40 x 1,5	6309 2Z
SLg 160L ...	60	305	300	40	200	M16	20	370	656	13	782	350	M 40 x 1,5	6309 2Z
SLg 180M ...	70	350	320	40	243	M16	26	408	705	13	825	358	M 40 x 1,5	6311 2Z
SLg 180L ...	70	350	320	40	205	M16	26	408	705	13	825	358	M 40 x 1,5	6311 2Z
SLg 200L ...	80	400	350	40	215	M16	32	428	754	16	873	388	M 40 x 1,5	6213 2Z 6311 2Z

Wymiar AB dla silników wielkości 132 z łapami odlewanymi wraz z korpusem wynosi 260 mm.

As to motors of size „132” the dimension AB amounts to 260 mm in case the feet are together with frame casted.

### Formy wykonania:

- IM 2001, IM 2011, IM 2031 - wg IEC 60034-7, PN-EN 60034-7
- IM B35, IM V15, IM V36 - wg IEC 60034-7, PN-EN 60034-7

### Mounting forms:

- IM 2001, IM 2011, IM 2031 - per IEC 60034-7
- IM B35, IM V15, IM V36 - per IEC 60034-7

### Wymiary montażowe silników z tarczą kołnierkową B14 Mounting dimensions for motors with flange B14

Typ Type	D,DA	E,EA	F,FA	GA,GC	B14						
					Kołnier Flange	M	N	P	S	LA	T
SKh 90 ...	24j6	50	8h9	27,0	FT130/C160	130	110j6	160	M8	10	3,5
					FT115/C140	115	95j6	140	M8	10	3,0
SKg 100 ...	28j6	60	8h9	31,0	FT165/C200	165	130j6	200	M10	12	3,5
					FT130/C160	130	110j6	160	M8	12	3,5
SKg 112 ...	28j6	60	8h9	31,0	FT165/C200	165	130j6	200	M10	12	3,5
					FT130/C160	130	110j6	160	M8	12	3,5
SKg 132 ...	38k6	80	10h9	41,0	FT215/C250	215	180j6	250	M12	12	4,0
					FT165/C200	165	130j6	200	M10	12	3,5
SKg 160 ...	42k6	110	12h9	45,0	FT265/C300	265	230j6	300	M12	13	4,0
					FT215/C250	215	180j6	250	M12	20	4,0

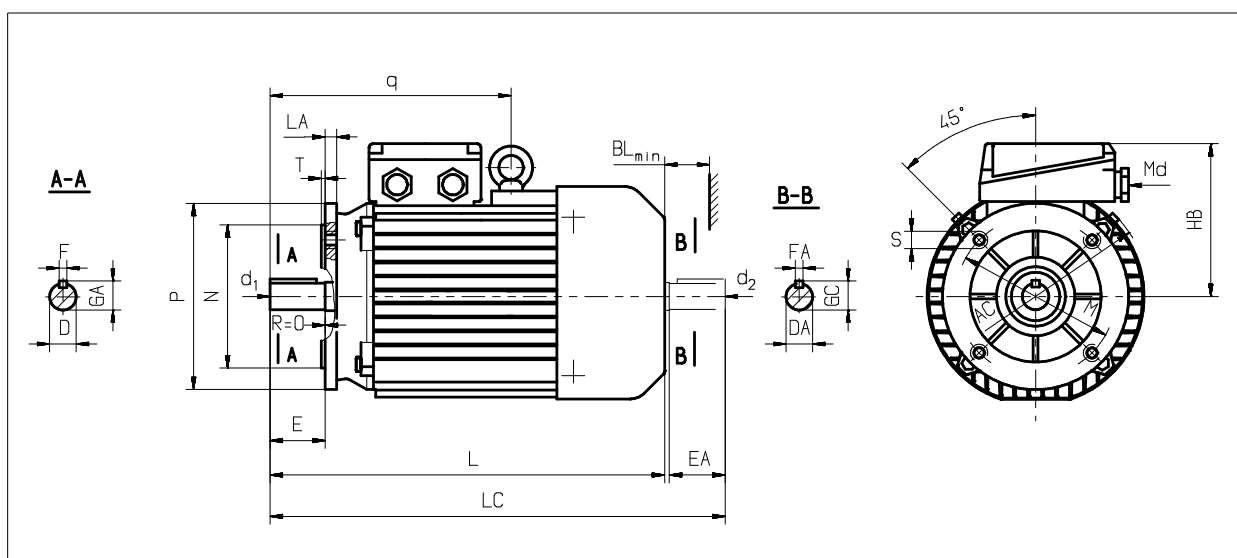

### Wymiary gabarytowe silników z tarczą kołnierkową B14 Overall dimensions for motors with flange B14

Typ Type	AC	BL	d1,d2	HB	L	LC	q	Md	Łożysko nr Bearing No
	[mm]								
SKh 90S ...	185	15	M8	130	305	360	-	M 20 x 1,5	6205 2Z
SKh 90L ...	185	15	M8	130	330	385	-	M 20 x 1,5	6205 2Z
SKg 100L ...	206	20	M10	140	376	441	-	M 20 x 1,5	6206 2Z
SKg 112M ...	245	20	M10	164	384	449	257	M 25 x 1,5	6306 2Z
SKg 132S ...	274	40	M12	178	463	549	284	M 25 x 1,5	6308 2Z
SKg 132S-2B	274	40	M12	178	501	587	284	M 25 x 1,5	6308 2Z
SKg 132M ...	274	40	M12	178	501	587	284	M 25 x 1,5	6308 2Z
SKg 160M ...	323	40	M16	210	612	738	350	M 40 x 1,5	6309 2Z
SKg 160L ...	323	40	M16	210	656	782	350	M 40 x 1,5	6309 2Z

Wymiary silników kołnierzowych na łapach IM B34 (oprócz tarczy kołnierzowej) – patrz tabele dla IM B35 na stronie 6

Dimensions for foot-flange motors IM B34 (except flange shield) – see tables for IM B35 on page 6

Wymiar AB dla silników wielkości 132 z łapami odlewanymi wraz z korpusem wynosi 260 mm.

As to motors of size „132” the dimension AB amounts to 260 mm in case the feet are together with frame casted.

Formy wykonania:

- IM 3601, IM 3611, IM 3631 - wg IEC 60034-7, PN-EN 60034-7
- IM B14, IM V18, IM V19- wg IEC 60034-7, PN-EN 60034-7

Mounting forms:

- IM 3601, IM 3611, IM 3631 - per IEC 60034-7
- IM B14, IM V18, IM V19- per IEC 60034-7